

97-15V

Glass Details

Option A

34.8mm Insulating Glass Unit, Comprising of:  
 6mm HST Toughened, Low 'E', Outer Pane,  
 20mm Warm Spacer Bar Black (Argon Filled Silicone Edge Seal).  
 8.8mm Clear Laminated (Ground Edges) Inner Pane.

Option B

34mm Insulating Glass Unit, Comprising of:  
 6mm Toughened, Low 'E', Outer Pane,  
 22mm Warm Spacer Bar Black (Argon Filled Silicone Edge Seal).  
 6mm Toughened, (Ground Edges) Inner Pane.

Frame Details

Extruded aluminum profile comprising of 2 parts, thermally broken  
 in the center. Internal and external sections PPC to RAL 7016.  
 Internal trim PPC to RAL 9010

Finish

External: PPC to RAL 7016  
 Internal: PPC to RAL 9010

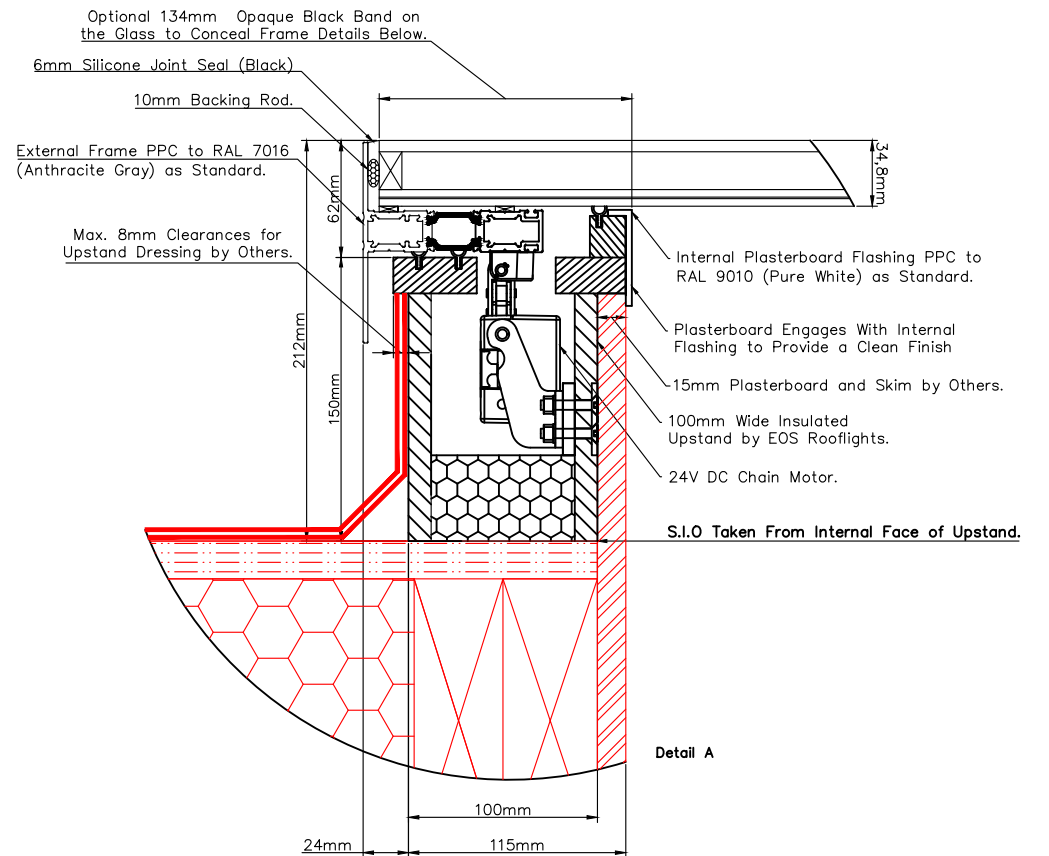
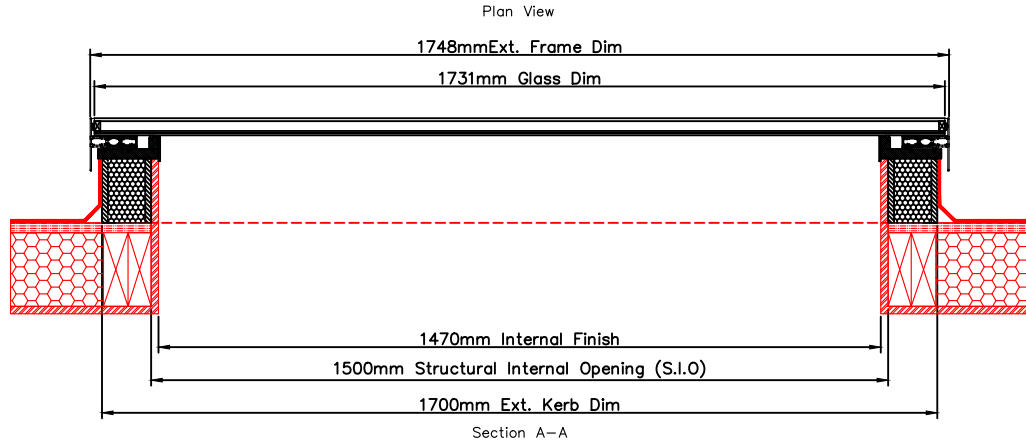
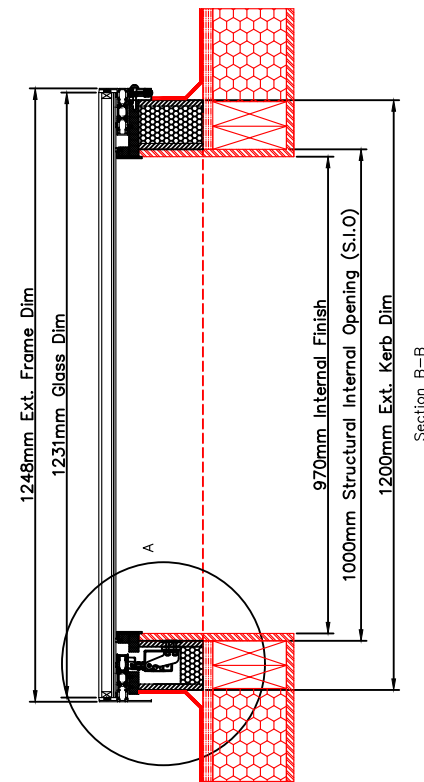
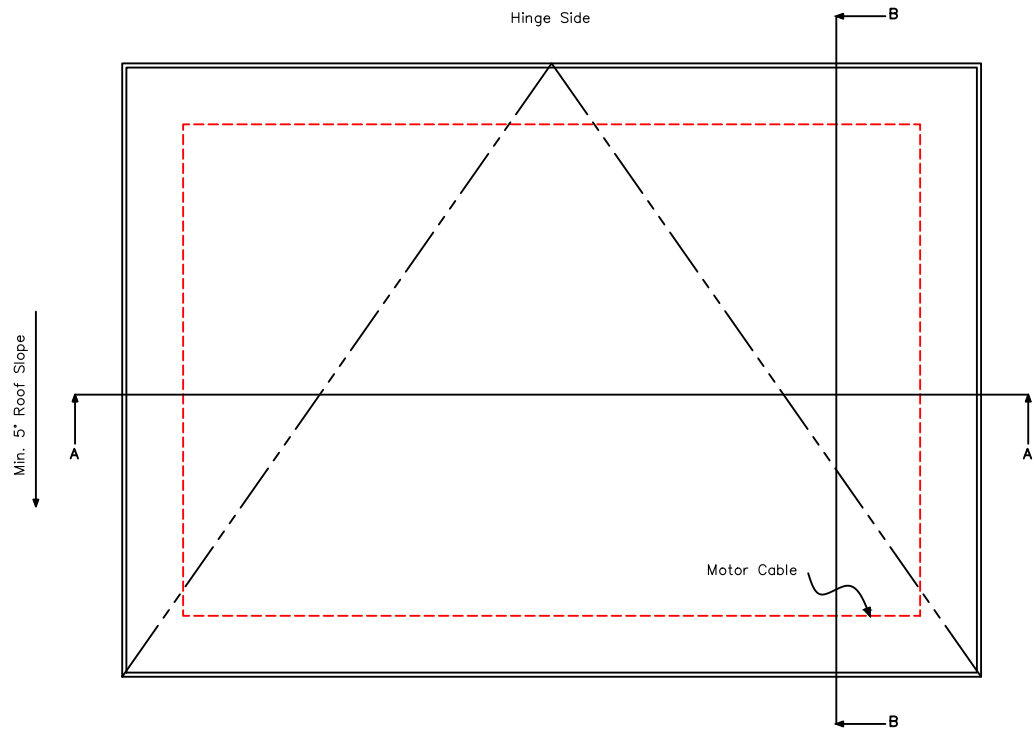

— = by Others  
 — = by EOS Rooflights



EOS Rooflights, Unit 2, Sidcup Logistics Park East  
 Sandy Lane, Sidcup, Kent, DA14 5FE  
 e: sales@eosrooflights.co.uk  
 w: www.eosrooflights.co.uk

Rev:	Description:	By:	Date:

Tolerance  
 Unless  
 Otherwise  
 Stated ±1mm.

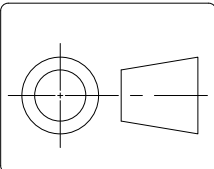

Project:  
 Stock EOS-97 Vent.

Description:  
 EOS-97 Vent to Suit 1000mm x 1500mm S.I.O.

Scale:  
 Not to Scale

Date:  
 19/02/2025

Drawn By:  
 AM

Drawing No:  
 GA-97VS-002

Revision:

Checked By:  
 CH